

Ambrogio Robot 4.50 RTK

MD-CO-RO-31- Rev. 1.0 - 30/10/2025 - Ambrogio Robot 4.50 RTK

Spare Parts Catalogue

Previous Revision
Current Revision

1.0
1.1

From

2025-10

Models Type Included

C450EL0

Ambrogio 4.50 RTK

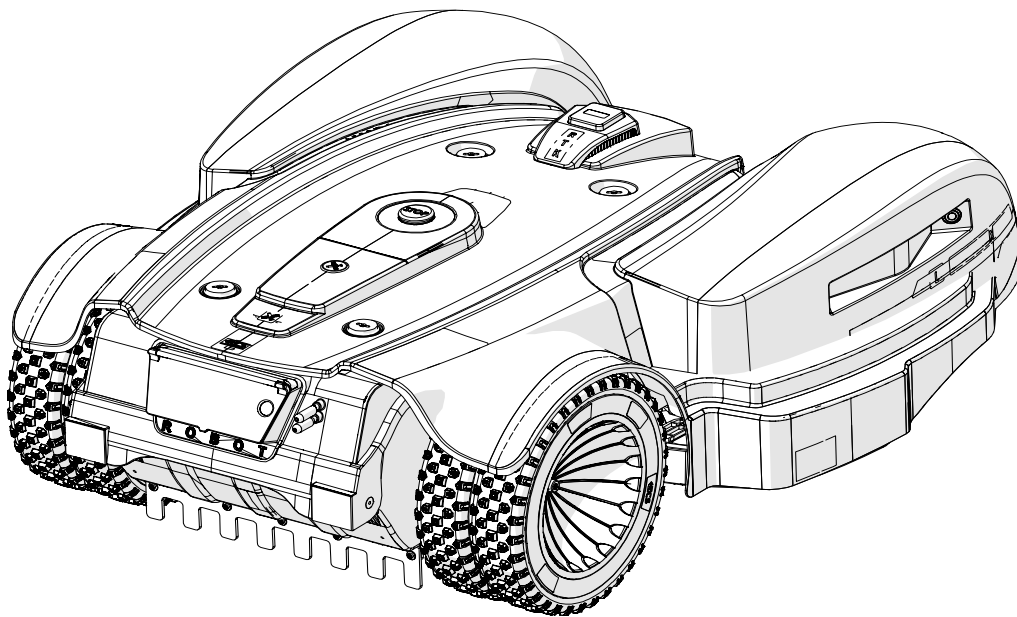

Tav.
Tab.
Taf.

01

0

Accessori - Accessory

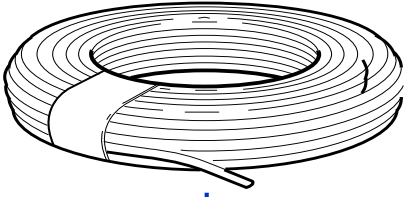

1



2

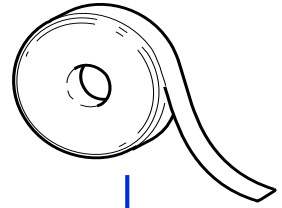

3

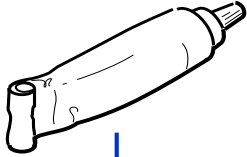

4

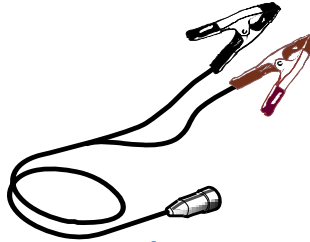

5

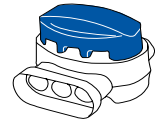

6

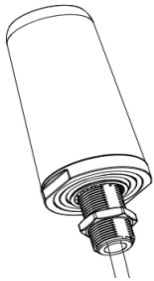

7

Tav.	01	0
Tab.		
Taf.		

Rif.	Code	Qt.in Robot		(IT) Descrizione * (GB) Description	MOQ
1	CS_E0002OS	1	MT 100	Cavo - Cable	1
1	CS_E0002	1	MT 150	Cavo - Cable	1
1	CS_E0002_3	1	MT 300	Cavo - Cable	1
1	CS_E0002_5	1	MT 500	Cavo - Cable	1
1	CS_E0002_10	1	MT 1000	Cavo - Cable	1

Consegna in 60 giorni dall'ordine - Delivery Time 60 days from order date

2	200A00100A	0-1	(100 Pz)	Conf. Chiodi - Nails Bag	1
2	200A00200A	0-1	(200 Pz)	Conf. Chiodi - Nails Bag	1
3	CS_C0111	0		Nastro Agglomerante - Stretch Electrical Tape	1
4	CS_C0109	0	200 Gr	Grasso - Grease	1
5	CB01RICINV3	0		Kit Ricarica Invernale - Kit for Winter Garaging	1
6	200A00003	1		(3pcs) - Connettore - Connector	1
6	200A00001	0		(10pcs) - Connettore - Connector	1
6	200A00050	0		(50pcs) - Connettore - Connector	1
7	400K00001A	0		Kit antenna GSM/LTE - Kit GSM/LTE antenna	1

Solo per rivenditori
Only for dealer

Code	(IT) Descrizione * (GB) Description	MOQ
CS_BT_USB	Convertitore USB-Bluetooth - USB-Bluetooth Converter	1



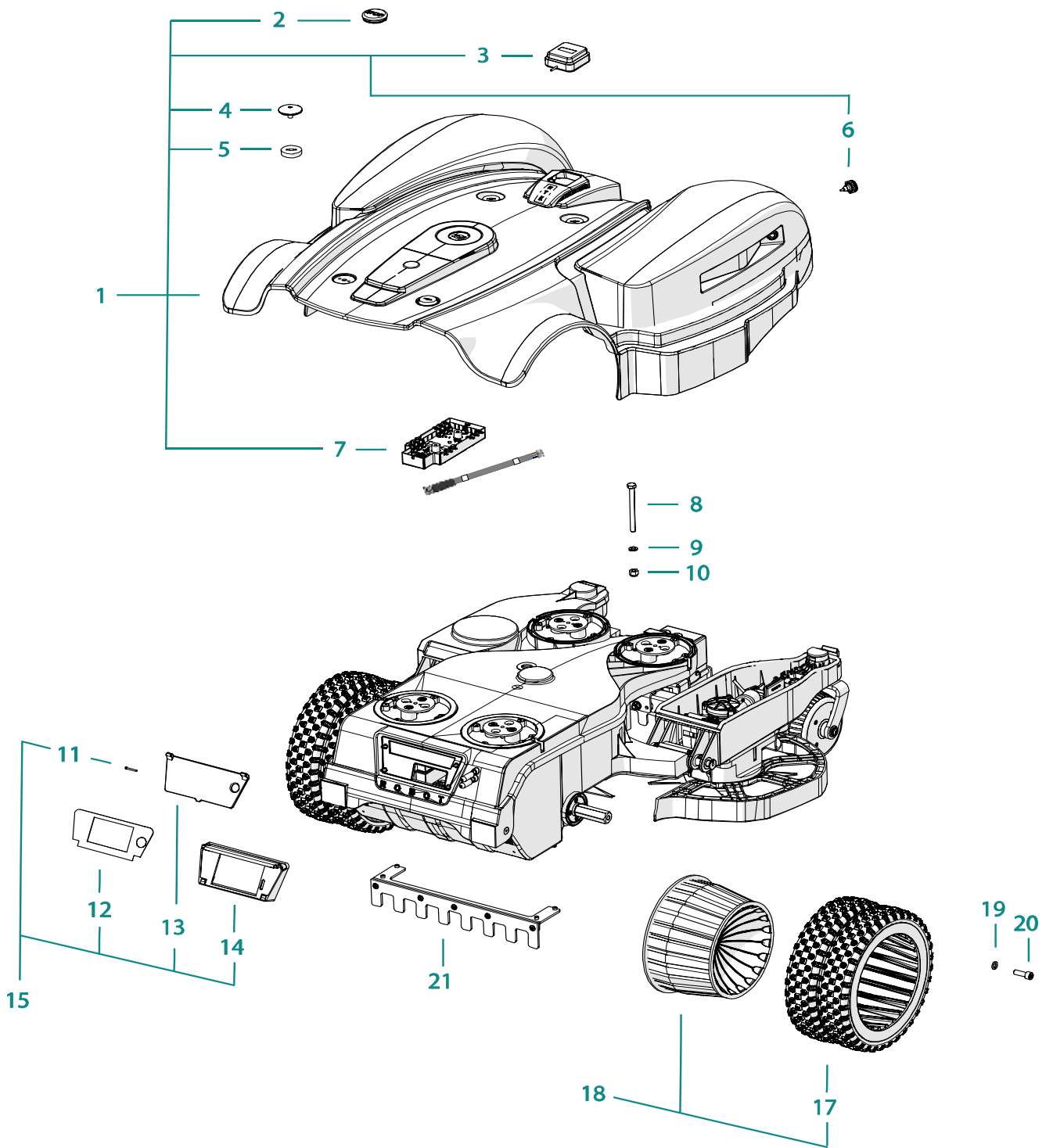

Tav.	02	0
Tab.		
Taf.		

Rif.	Code	Qt.in Robot		(IT) Descrizione * (GB) Description	MOQ
1	400Z95194A_R	1	Ambrogio	Gruppo calotta - Cap set	1
2	110E01300B	1		Tasto Stop - Stop key	1
3	400Z95477A_R	1		Antenna RTK - RTK Antenna	1
4	400Z10900A	4		Vite - Screw	1
5	025_D0080.4	4		Guarnizione - Gasket	1

For robots before s/n xx450xxx25030015

6	400Z95519A_R	13		(TDK) Sensore USS - (TDK) USS Sensor	1
Use with HUB ref.7 TDK and rif. 16 TDK					

For robot from s/n xx450xxx25030015

6	400Z95749A_R	13		(HTW) Sensore USS - (HTW) USS Sensor	1
Use with HUB ref.7 HTW and rif. 16 HTW					

7	400Z78612A_R	1	TDK	Modulo HUB USS - USS HUB module	1
7	400Z78612A_R2	1	HTW	(R2) Modulo HUB USS - (R2) USS HUB module	1
8	C01484	2		Vite - Screw	10
9	C01485	2		Rondella - Washer	10
10	C01486	2		Dado M8 - Nut M8	10
11	300Z35400A	2		Vite - Screw	8
12	300Z36200A	1		Pellicola display - Display film	1
13	400Z51100A_R	1		Cover display - Display cover	1
14	300Z37700B_R	1		Supporto display - Display support	1
15	300Z36300B_R	1		Gruppo supporto display - Display holder kit	1
17	400Z55800A	2		Copertone in gomma - Rubber tire	1
18	400Z55600A	2		Ruota trazione - Traction wheel	1
19	C00217	2		Rondella - Washer	10
20	C02251	2		Vite - Screw	10
21	400Z00761A_R	1		Assieme gomma posteriore - Rear rubber assembly	1

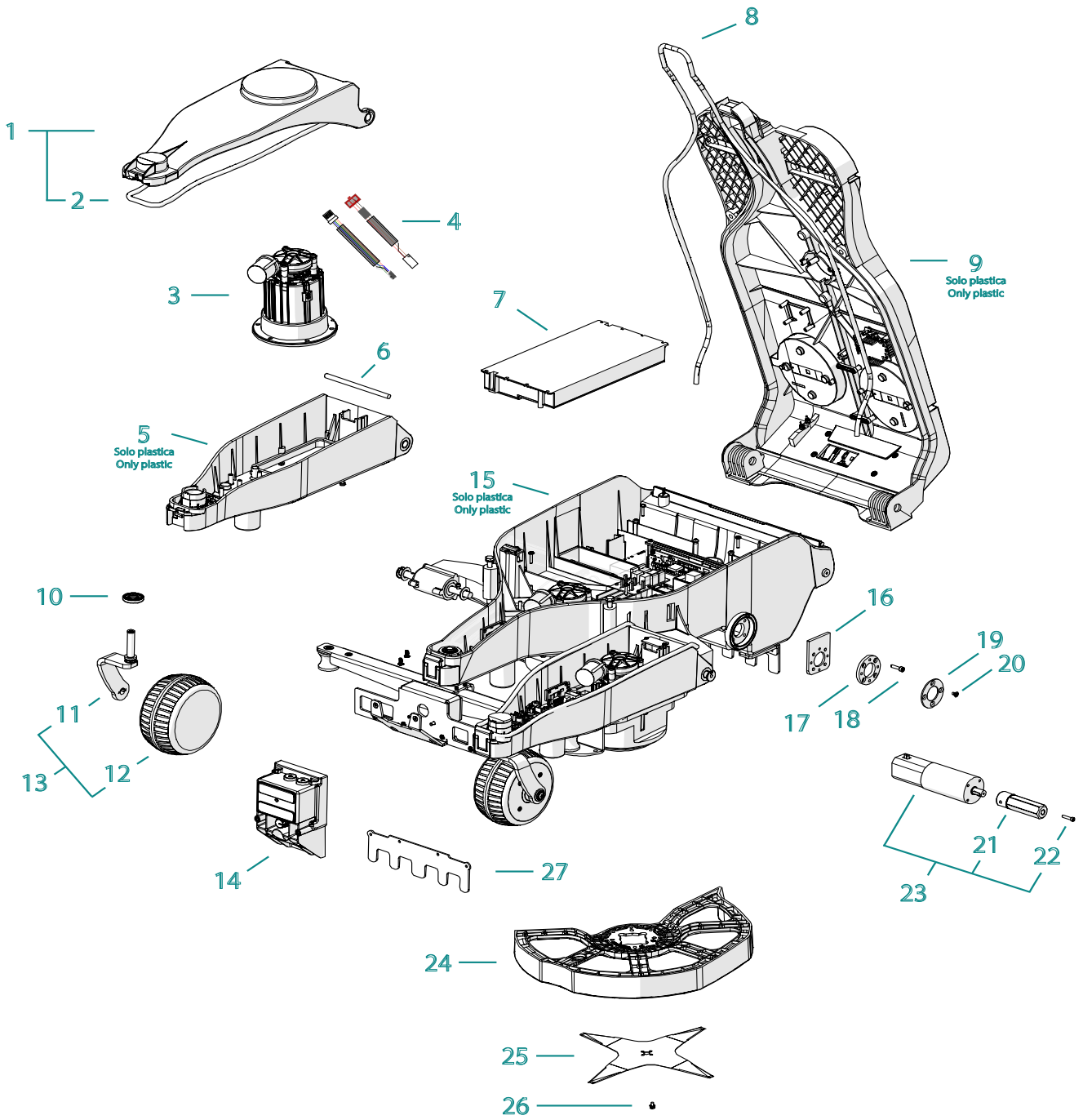

Rif.	Code	Qt.in Robot		(IT) Descrizione * (GB) Description		
1	400D00019	2		Cover Braccio - Arm Cover		1
2	400Z18500A	2		Guarnizione - Gasket		1
3	075Z37600A	3		Motore lama - Blade motor		1
4	051CB04.01	3		Adattatore cablaggio motore - Motor cabling adapter		1
5	400Z72000A_R	2		Chassis inferiore braccio - Arm lower chassis		1
6	400Z18600A	2		Guarnizione - Gasket		10
7	300Z42800A_R	4		(15Ah) Batteria - Battery		1
8	C00983	1		Guarnizione - Gasket		1
9	400Z95220A_R	1		Scocca superiore - Upper body		1
10	110Z43500A	2		Soffietto - Bellows		1
11	400Z72400A_R	1	Dx	Staffa ruota - Wheel support		1
11	400Z72200A_R	1	Sx	Staffa ruota - Wheel support		1
12	400Z51800A	2		Gruppo ruota frontale - Front wheel group		1
13	400Z72500A_R	1	Dx	Assieme ruota frontale - Front wheel assembly		1
13	400Z72300A_R	1	Sx	Assieme ruota frontale - Front wheel assembly		1
14	400Z70000A_R	1		Modulo ricarica - Recharge module		1
15	400Z56700A	1		Chassis inferiore centrale - Central lower chassis		1
16	400Z45200A	2		Staffa - Support		1
17	400Z02600A	2		Supporto Ruota - Wheel support		1
18	C03349	8		Vite - Screw		10
19	400Z95814A_R	2		Piastra - Plate		1
20	C03348	8		Vite - Screw		10
21	400Z45400A	2		Esagono - Hexagon		1
22	C02087	2		Vite - Screw		10
23	400Z50400A	2		Motoriduttore - Motor Reducer		1
24	400Z95472A_R	1	Sx	Paralama - Blade protection		1
24	400Z95473A_R	1	Dx	Paralama - Blade protection		1
25	075Z56500A_R	3		Lama piegata 4 punte - 4 knife blade		1
26	C00212	12		Vite - Screw		100
27	400Z00763A_R	1		Gomma anteriore - Front rubber		1

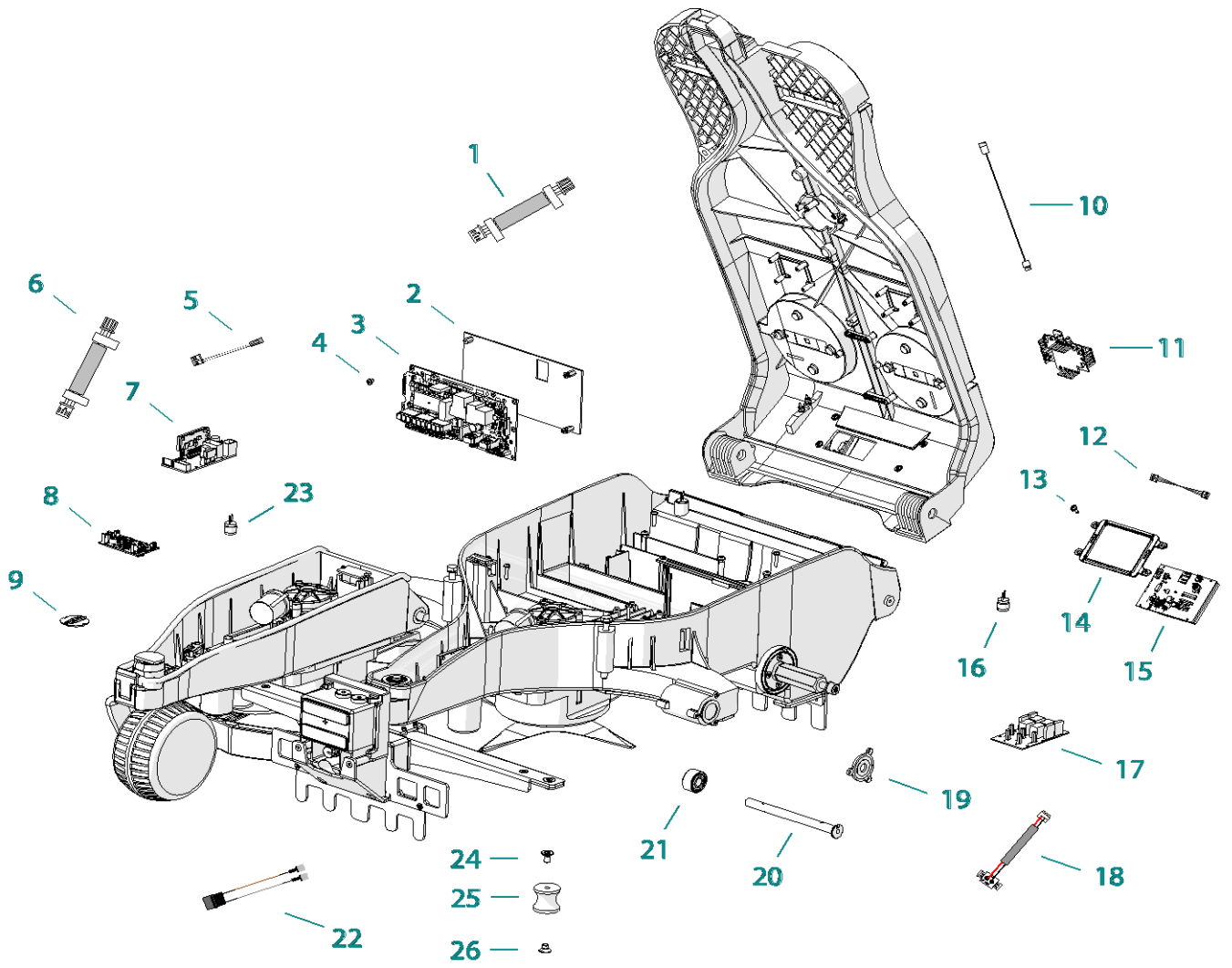

Rif.	Code	Qt.in Robot		(IT) Descrizione * (GB) Description	MOQ
1	400CB02.01	1	G, H, I	Cablaggi CAN-bus - CAN-bus wiring	1
2	400Z50900A	1		Supporto - Support	1
3	400E05000A	1		Scheda Madre - Mother Board	1
4	C00568	4		Vite - Screw	100
5	110E01100A	1		Cablaggio Terminazione CAN - CAN termination cable	1
6	CB10_L400.1	2	A	Cablaggio - Wiring	1
7	400E05300B_R	3		Driver con alzalama - Driver with blade raiser	1
8	400E04300A	2		(RX-C1) Ricevitore - Receiver	1
9	400E05303A_R	2		Scheda LIFT - LIFT sensor	1
10	CB07_L400.2	1		Cablaggio GPS - GPS Cabling	1
11	042Z95654A_R	1		Modulo Connect RTK - RTK Connect module	1
11	042Z00945A_R	1		Modulo RTK (1NCE) - RTK Module (1NCE)	1
12	CB01_DIS4000	2		Cablaggio - Wire	1
13	C00568	4		Vite - Screw	100
14	300Z33000A	1		Supporto - Support	1
15	400Z47700A	1		Display - Display	1
16	110A00100A	2		Bobina - Coil	1
17	400E03600A	1		HUB Batteria - HUB Battery	1
18	400CB01.01	1		Cablaggio HUB-Driver - HUB-Driver wiring	1
19	400Z02000A	2		Coperchio cerniera - Hinge cap	1
20	400Z02400A	2		Perno cerniera braccio - Pivot arm hinge	1
21	C00030	4		Cuscinetto - Bearing	1
22	042CB09.03	1		Connettore ricarica esterna - External recharge connector	1
23	400E04500B_R	4		Bobina - Coil	1
24	C03027	2		Vite - Screw	10
25	C02680_R	2		Antivibrante - Silentblock	1
26	C03026	2		Vite - Screw	10

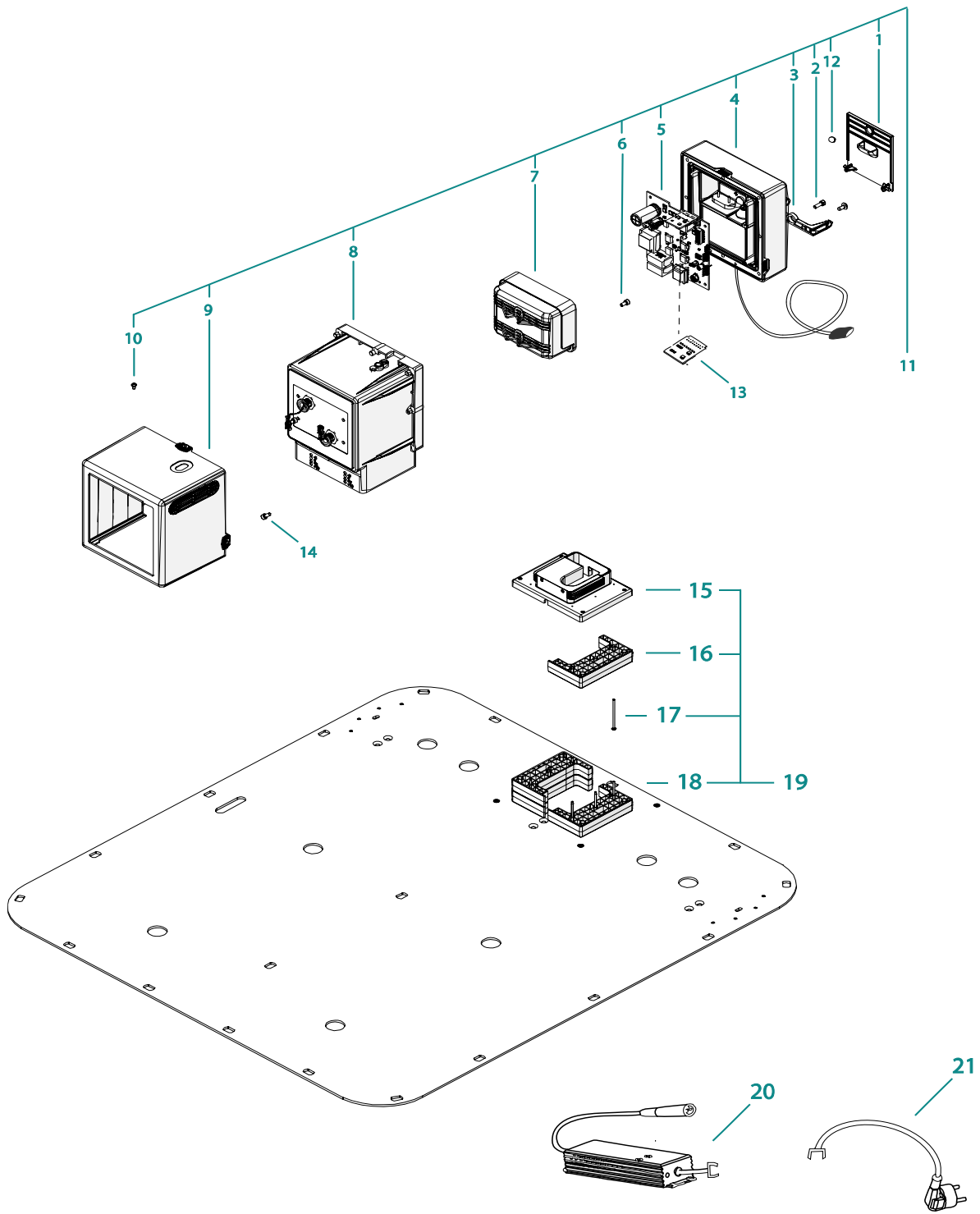

Tav.	05	0
Tab.		
Taf.		

Rif.	Code	Qt.in Robot		(IT) Descrizione * (GB) Description	MOQ	
1	042Z37200A	1		Coperchio posteriore - Back cap	1	
2	C02172	8		Vite - Screw	10	
3	042Z24500A	1		Fermacavo - Cable clamp	1	
4	042Z27300A	1		Chiusura base ricarica - Docking Station Closing	1	
5	042E00500A	1		Trasmettitore - Trasmettiter	1	
6	C02224	4		Vite - Screw	10	
7	042Z24800A	1		Gruppo contatti ricarica - Recharging contact group	1	
8	042Z44500A	1		Torretta base di ricarica - Docking Station Tower	1	
9	042Z53000A	1		Copertura torretta - Tower cover	1	
10	C02244	3		Vite - Screw	10	
11	042Z26500A	1		Box trasmettitore (Bianco) - Transmitter box (White)	1	
12	042Z32000A	1		Magnete - Magnet	1	
13	015A00700A	1		Scheda LED trasmettitore - LED transmitter board	1	
14	C00908	2		Vite - screw	10	
15	042Z23700A_R	1		Supporto torretta ricarica - Support for recharge turret	1	
16	042Z58900A	2		Distanziale - Spacer	1	
17	C03090	6		Vite - Screw	10	
18	400Z95203A_R	1		Pianale ricarica - Base station floor	1	
19	400Z95204A_R	1		Base ricarica completa - Base station assembly	1	
20	NPB-360-24ZCT	1		(12A) Alimentatore - (12A) Power supply	1	
21	50_C0008_00	1	Schuko	Cavo Alimentazione - Supply Cable	1	
21	50_C0004_00	1	USA	Cavo Alimentazione - Supply Cable	1	
21	50_C0011_00	1	GB	Cavo Alimentazione - Supply Cable	1	
21	50_C0012_00	1	CH	Cavo Alimentazione - Supply Cable	1	